

# ***Nikon***

**Slide Feeder**

**SF-200**

**Reference Manual**

## Cautions

- The reproduction of this manual in whole or in part is prohibited save in cases in which Nikon's prior permission has been obtained.
- The information contained in this manual is subject to change without notice.
- Nikon has made every effort to produce a perfect manual, but should you find any mistakes, we would be grateful if you would kindly let us know. The address of the Nikon representative in your area is provided separately.
- Nikon is not liable for damages resulting from the use of this product.

### Trademark Information

All trade-names mentioned in this manual are the trademarks or registered trademarks of their respective holders.

### Symbol

The  symbols in this manual signify important safety precautions. All passages marked with this indication should be read prior to installation to prevent injury to yourself or to others. These indications are also placed in the table of contents to mark passages that should be read before use.

### Symbol

The  symbols in this manual signify the need for caution when using the products. These indications are placed in sections that should be read before operation to prevent damage to the product.

## Federal Communications Commission (FCC) Radio Frequency Interference Statement

This equipment has been tested and found to comply with the limits for a Class B digital device, pursuant to Part 15 of the FCC Rules. These limits are designed to provide reasonable protection against harmful interference in a residential installation. This equipment generates, uses, and can radiate radio frequency energy and, if not installed and used in accordance with the instructions, may cause harmful interference to radio communications. However, there is no guarantee that interference will not occur in a particular installation. If this equipment does cause harmful interference to radio or television reception, which can be determined by turning the equipment off and on, the user is encouraged to try to correct the interference by one or more of the following measures:

- Reorient or relocate the receiving antenna.
- Increase the separation between the equipment and receiver.

- Connect the equipment into an outlet on a circuit different from that to which the receiver is connected.
- Consult the dealer or an experienced radio/television technician for help.

## **CAUTIONS**

### **Modifications**

The FCC requires the user to be notified that any changes or modifications made to this device that are not expressly approved by Nikon Corporation may void the user's authority to operate the equipment.

### **Notice for customers in Canada**

#### **CAUTION**

This class B digital apparatus meets all requirements of the Canadian Interference Causing Equipment Regulations.

#### **ATTENTION**

Cet appareil numérique de la classe B respecte toutes les exigences du Règlement sur le matériel brouilleur du Canada.

### **Notice for customers in European countries**

#### **ACHTUNG**

Dieses Gerät entspricht den Bestimmungen der EG-Direktive 87/308/EEC zur Störungsunterdrückung. Lärmemission kleiner 70 dBA

### **Notice concerning prohibition of copying or reproduction**



Note that simply being in possession of material which has been copied or reproduced by means of a scanner may be punishable by law.

- **Items prohibited by law from being copied or reproduced**  
Do not copy or reproduce paper money, coins, securities, government bonds, or local government bonds, even if such copies or reproductions are stamped "Sample".  
The copying or reproduction of paper money, coins, or securities which are circulated in a foreign country is prohibited.  
Unless the prior permission of the government has been obtained, the copying or reproduction of unused postage stamps or post cards issued by the government is prohibited.  
The copying or reproduction of stamps issued by the government and certified documents stipulated by law is prohibited.
- **Cautions on certain copies and reproductions**  
The government has issued cautions on copies or reproductions of securities issued by private companies (shares, bills, checks, gift certificates, etc.),

commuter passes, or coupon tickets, except when a minimum of necessary copies are to be provided for business use by a company. Also, do not copy or reproduce passports issued by the government, licenses issued by public agencies and private groups, ID cards, and tickets, such as passes and meal coupons.

- **Comply with copyright notices**  
The copying or reproduction of copyrighted creative works such as books, music, paintings, woodcut prints, maps, drawings, movies, and photographs is prohibited except when it is done for personal use at home or for similar restricted and non-commercial use.

# Contents

	<b>1. Overview .....</b>	<b>5</b>
	<b>2. Parts and Accessories.....</b>	<b>6</b>
	2.1 Package Contents .....	6
	2.2 Parts of the SF-200 .....	7
	<b>3. Installation .....</b>	<b>7</b>
	<b>4. Using the SF-200 .....</b>	<b>10</b>
	4.1 Loading the feeder .....	10
	4.2 Removing slides .....	12
	4.3 Using the Feed-Mechanism Attachment .....	13
	4.4 What to do if the feeder jams .....	15
	If You Should Notice Anything Unusual .....	16
	<b>5. Maintenance .....</b>	<b>17</b>
	5.1 Cleaning .....	17
	5.2 Storage .....	17
	5.3 Transport .....	17
	<b>6. Specifications .....</b>	<b>18</b>

# 1. Overview

Thank you for your purchase of an SF-200 slide feeder for the LS-2000 Nikon film scanner. The SF-200, which can hold up to fifty mounts 1.5 mm in thickness, automates the scanning of consecutive 35 mm slides. Like the other adapters for the LS-2000, the SF-200 can be inserted while the scanner is on and connected to a computer.

This manual describes the procedures for unpacking, setting up, and connecting the feeder to your scanner. The next chapter, “*Parts and Accessories*,” details the contents of the package and the parts of the feeder. This is followed by “*Installation*,” which describes how to connect the feeder to the scanner. In “*Using the SF-200*,” the procedures for loading and removing slides are explained. The final chapter, “*Maintenance*,” gives instructions on how to care for and transport the feeder. Please read all instructions thoroughly to ensure that you can get the most from your SF-200.

The procedures for scanning consecutive slides with the SF-200 may be found in the software reference manuals provided on the CD-ROM that came with your scanner.

We hope that you find this manual helpful.

## 2. Parts and Accessories

This chapter lists the items packaged with your slide feeder and identifies the parts of the SF-200.

### 2.1 Package Contents

Purchasers of the SF-200 should find that the package contains all the items listed below. Should you find that anything is missing or damaged, contact your retailer immediately.

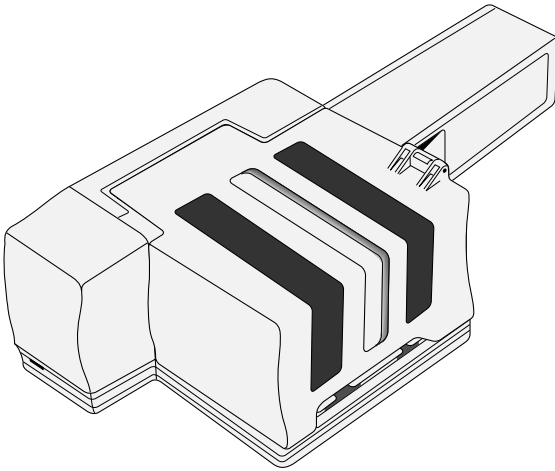

SF-200 slide feeder  
(1)

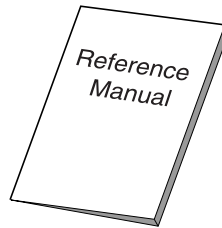

Reference manual (this manual)  
(1)



Feed-mechanism attachment  
for rounded slide mounts (1)

## 2.2 Parts of the SF-200

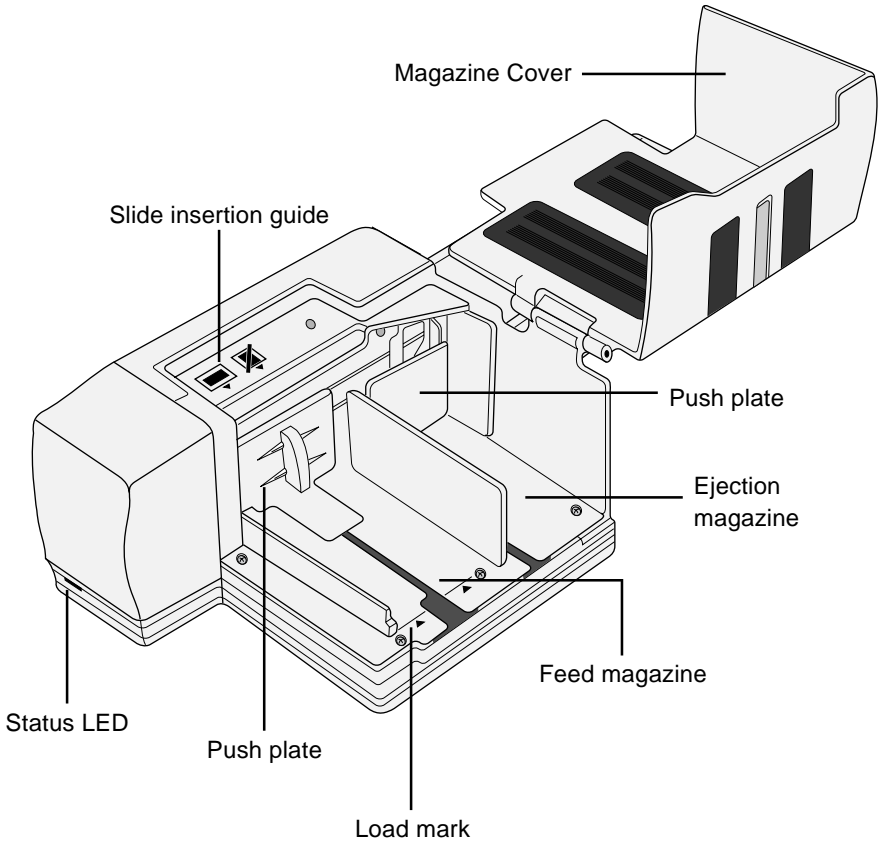

## 3. Installation

Before installing the SF-200, make sure that your scanner is set up in a suitable location, as described in the *Fast Track Guide* and reference manual provided with the scanner. The SF-200 should not be used where:

- the temperature exceeds 35°C (95°F) or falls below 10°C (50°F)
- it would be subject to condensation or drastic changes in temperature
- the humidity exceeds 85%
- it would be exposed to direct or reflected sunlight

- it might be subject to vibration or strong physical shocks
- there is a lot of dust
- it would be exposed to radio interference from other electronic devices



**Warning:** *Failure to observe the above precautions could result in fire or in scanner malfunction.*

The scanner must be on its base when the SF-200 is used, and there must be sufficient space around the scanner to allow the magazine cover to open and to ensure adequate ventilation. There should be at least 15 cm (6") of space above the unit and 10 cm (4") open to the rear. Space requirements when the SF-200 is attached are illustrated below.

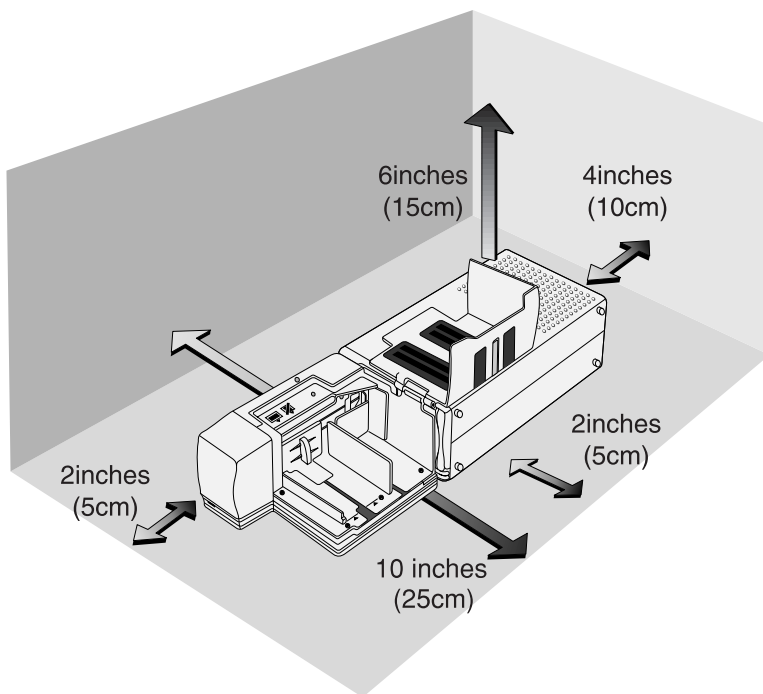

The SF-200 can be mounted on the scanner whether the scanner is off or on and connected to a computer. If the scanner is on, before mounting the feeder check that the status LED is glowing steadily. The SF-200 should NOT be inserted or removed while the status LED is blinking.



The scanner must be on its base before the SF-200 can be inserted. If the scanner is currently installed on its side, turn the scanner onto its base, with the power switch to the left when viewed from the front. Slide the SF-200 into the scanner's adapter slot, stopping when the feeder contacts the back of the slot. The feeder should be oriented as shown below when inserted. Push the feeder until the connector on the rear of the feeder is seated securely in the socket at the back of the slot. The feeder is properly inserted if the status LED on the front of the feeder lights when the scanner is turned on. If the scanner is on when the feeder is inserted, the feeder's status LED will blink once to indicate that the feeder has been inserted correctly. In all other respects, the feeder LED functions in the same way as the scanner status LED.

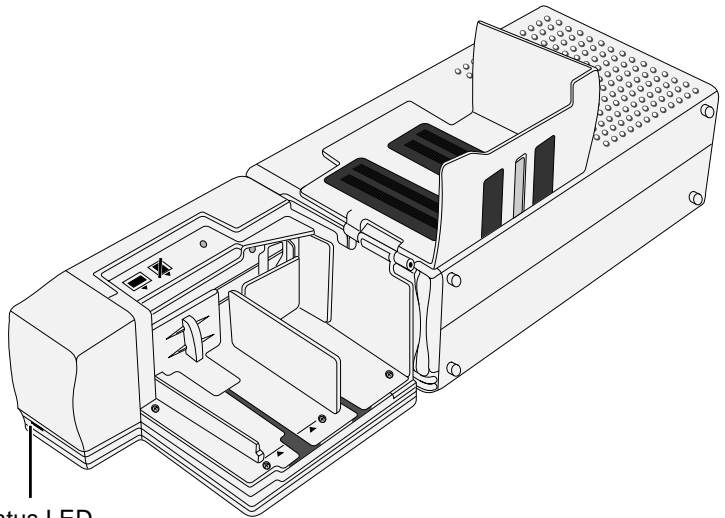

Status LED

If the SF-200's feed mechanism is not in the initial position when the scanner is turned on, you will need to wait a few seconds for the feed mechanism to return to initial position before inserting slides.



## Cautions

- Wait until the status LED glows steadily or the scanner is off before inserting or removing the SF-200. Do not attempt to remove or insert the feeder while the scanner is operating.
- When the SF-200 is inserted with the power on, or the scanner

turned on after the feeder has been inserted with the power off, the feed mechanism will return to the initial position. While this operation is in progress, the status LED on the front of the feeder will blink. Do not perform any operations while the LED is blinking.

- If the feeder does not slide in smoothly, remove it from the adapter slot and try again. Do not use force.

## 4. Using the SF-200

This chapter describes how to load the SF-200, how to remove slides, and how to deal with jams.

### 4.1 Loading the feeder

Slides to be scanned are inserted in the feed magazine. To load the magazine, open the magazine cover, pull back the feed push-plate to the end of its groove, and hook it in the notch so that it does not spring back to its original position. Place the slides in the magazine with the long end of the aperture up and the emulsion surface facing the push plate (the images in the slides should be reversed when viewed from the magazine side). Scanning will be considerably simplified if the slides are all inserted in the same orientation.

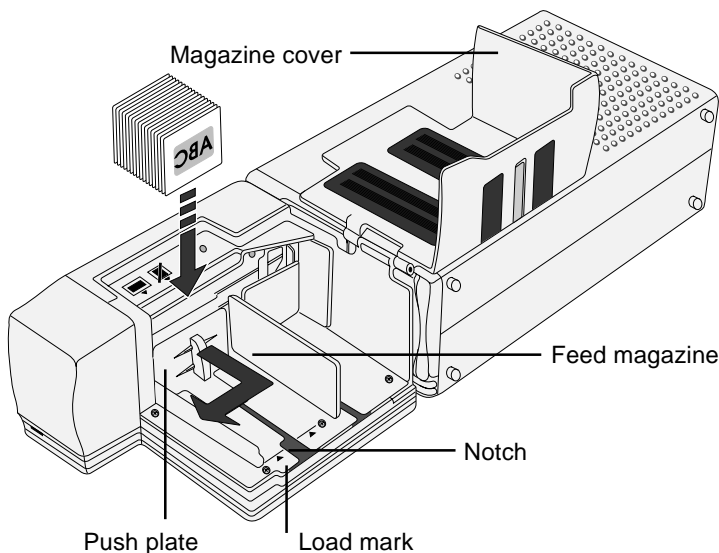

Slides can be loaded into the feed magazine up to the load mark. Do not attempt to fill the magazine past this point. Once the feed magazine is loaded, release the push plate from the notch and slide it back until it rests against the slides.

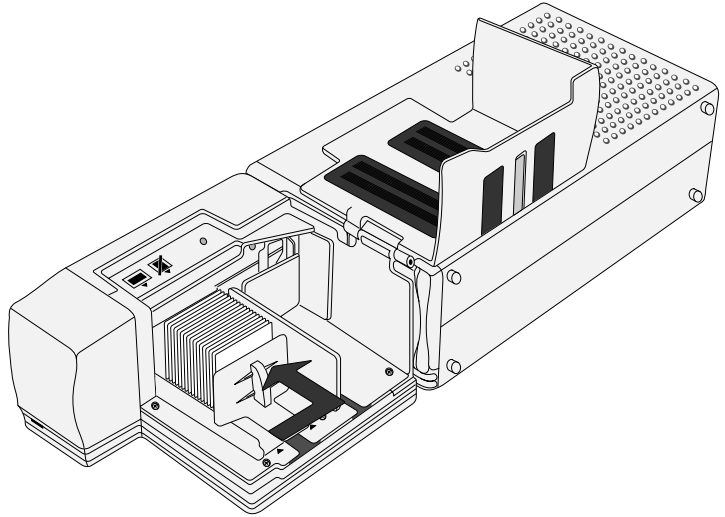

Close the magazine cover. You are now ready to begin scanning. For details on automatic consecutive scanning of multiple slides, refer to the software reference manual.



## Cautions

- Slides must be from 1.0 mm to 3.2 mm thick.
- Mounts with rough surfaces could cause the feeder to jam.
- Do not use mounts with peeling or burred edges, mounts to which seals or labels have been affixed, or mounts with sharp corners. Such mounts could jam the feeder or cause problems during scanning.
- Avoid slides with warped mounts. Warped slides may jam if placed in the feeder as shown below.

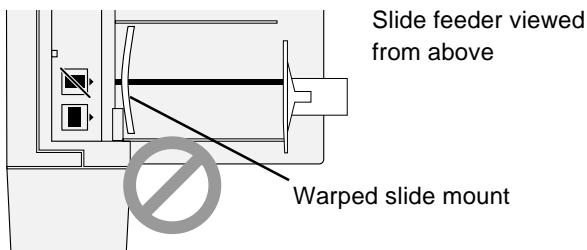

- The feeder does not function equally well with all makes of slide mount. Makes that have projecting parts or are not of an even thickness may jam in the feeder.
- Do not load slides into the feeder with the longer side of the aperture facing the scanner, as this could damage the film or slide mount or cause the feeder to jam. Insert slides as shown by the insertion guide sticker next to the feed magazine (see illustration on page 10).

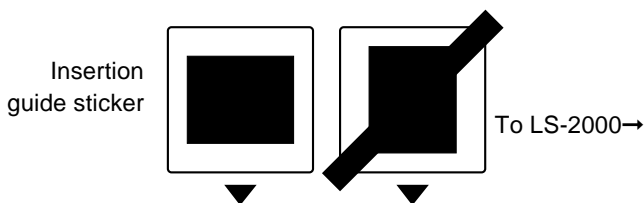

- Do not load slides in the feed magazine past the load mark, as this may cause the feeder to jam.
- Do not move the scanner while scanning is in progress.
- Remove scanned slides from the ejection magazine before the magazine is full. Continuing scanning when there is no room left in the ejection magazine could jam the feeder.
- Do not remove the feeder while scanning is in progress.
- Before turning the scanner off or removing the feeder, make sure that all slides have been removed from the magazine and that the last slide to be fed has been ejected.

## 4.2 Removing slides

Slides will be sent to the ejection magazine after scanning. To remove slides from the ejection magazine, pull back the push plate and remove the slides. Slides must be removed before the ejection magazine fills up.

### 4.3 Using the Feed-Mechanism Attachment

Thick mounts (over 2 mm thick) with rounded edges may not feed properly when used with the SF-200. A removable plastic part is provided for attachment to the feed mechanism, enabling the scanner to feed such slides. A special attachment utility program, provided with the Nikon Scan software that came with your scanner, is required both when attaching this part to and removing it from the feed mechanism.

To attach the feed-mechanism attachment, both your scanner and computer must be on. After inserting the SF-200 into the scanner as described above, open the **Utility** folder in the folder to which you installed Nikon Scan and then double-click the **Attachment Utility** icon to start the attachment utility.

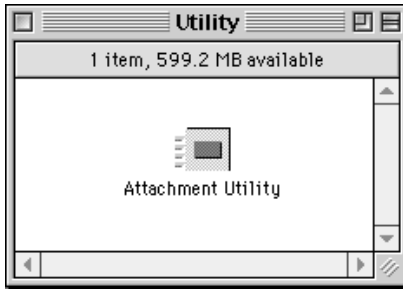

The attachment utility window will appear on the desktop. If more than one scanner is attached to your computer and powered on, select the scanner to which the SF-200 is attached from the **select a scanner** pop-up menu.

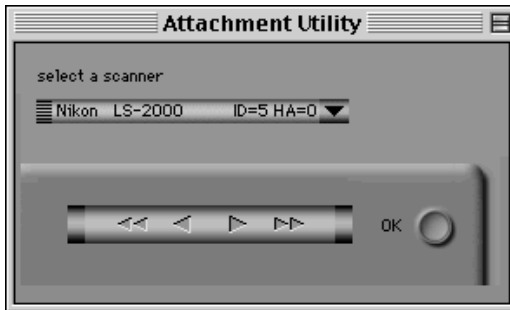

Open the SF-200's magazine cover, pull back the feed push-plate to the end of its groove, and hook it in the notch so that it does not

spring back to its original position.

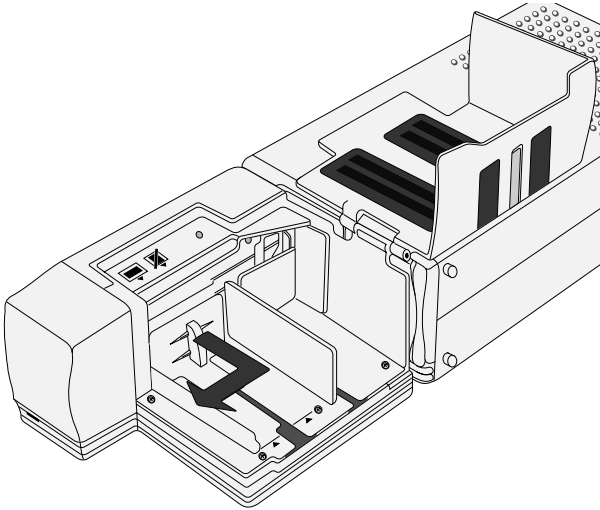

Click the double right-arrow button in the attachment utility to move the feed mechanism to where it is fully visible. If you move the feed mechanism too far, click the left-arrow button to move it back. The single-arrow buttons can be used for fine adjustments. Once the feed mechanism is visible, insert the pegs on the attachment into the holes in the feed mechanism.

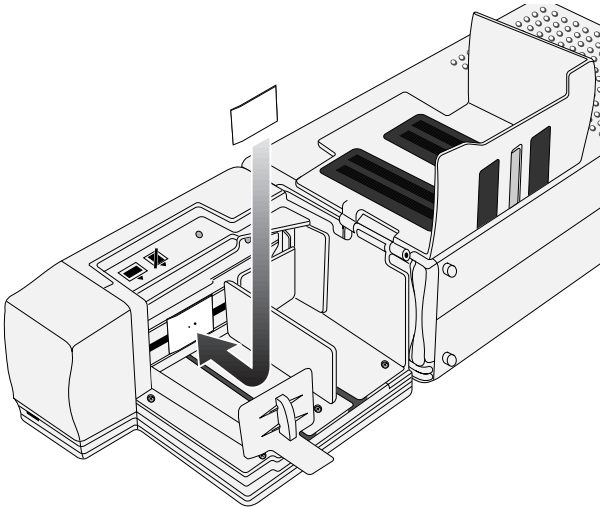



**Caution:** *Be sure that the attachment is securely in place. If the attachment is loose, slides may not feed properly and damage to the SF-200 could result.*

Click the **OK** button in the attachment utility window to return the feed mechanism to its initial position. You are now ready to begin scanning.

When scanning slides with flat mounts or slides less than 2 mm thick, you will need to remove the attachment. Use the attachment utility as described above to move the feed mechanism into the magazine, then remove the attachment and click **OK** to return the feed mechanism to its initial position.

#### 4.4 What to do if the feeder jams

If a jam occurs, open the magazine cover and remove the slides remaining in the feed and eject magazines. Pull back the feed push-plate and hook it in the notch so that it does not spring back to its original position.

The method for resolving a jam depends on the position of the feed mechanism when the jam occurred. If the jammed slide is visible in the magazine and the feed mechanism has returned to its housing in the front of the unit, the jammed slide can be removed with your fingers. If the feed mechanism has locked while feeding a slide, you will need to use the attachment utility to resolve the jam (the attachment utility is a special program for the SF-200 distributed with the Nikon Scan software that came with your scanner).

To use the attachment utility, open the **Utility** folder in the folder to which you installed Nikon Scan and double-click the **Attachment Utility** icon to start the attachment utility.

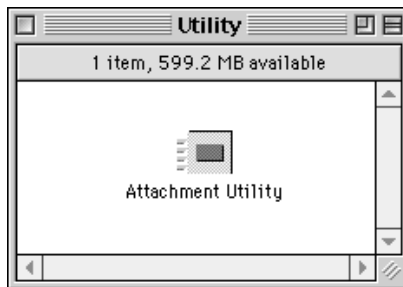

The attachment utility window will appear on the desktop. If more than one scanner is attached to your computer and powered on, select the scanner to which the SF-200 is attached from the **select a scanner** pop-up menu.



If the feed mechanism has locked while pushing a slide, click the double left-arrow button in the attachment utility window to move the feed mechanism back to its housing, then remove the jammed slide with your fingers. If two or more slides have jammed so that they overlap, remove the slide on the magazine side first. If the mount has caught at the entrance to the ejection magazine while being ejected from the feeder, click the right arrow button to move the feed mechanism out of the way, then push the slide back gently back towards the scanner to clear the jam. Using the left-arrow button, return the feed mechanism to its housing (if this does not clear the jam, you will need to take the feeder to a Nikon service center for repairs).



### **If You Should Notice Anything Unusual**

Should you notice an unusual noise, smell, or smoke coming from the feeder or scanner, immediately turn off the scanner and then unplug the power cord. Continued use could result in fire or electric shock. After ensuring that the equipment is no longer smoking, contact your dealer or Nikon representative for information on replacement or repairs. Do NOT attempt repairs yourself.



## 5. Maintenance

This chapter describes how to clean, store, and transport the SF-200.

### 5.1 Cleaning

Before cleaning the feeder, remove it from the scanner. The exterior of the feeder is made of plastic, and should not be cleaned with volatile cleaners such as alcohol or paint thinner. Use a blower to blow off dust or wipe the surface with a dry cloth. If this is not sufficient to remove all dirt, clean with a cloth that has been slightly dampened with a neutral detergent or liquid soap.



**Warning:** *Do not use water or a volatile liquid such as alcohol, benzene, or thinner. Should any of these liquids enter the feeder, fire or electric shock could result. Volatile chemicals could also stain the plastic exterior of the feeder.*

### 5.2 Storage

When you do not plan to use the feeder for an extended period of time, remove it from the scanner. Store in a dry, well-ventilated environment, away from electronic equipment such as televisions or radios which produce strong magnetic fields. Do not store the feeder where the temperature exceeds 60°C (140°F) or goes below -20°C (-4°F), or where the humidity is less than 20% or more than 90%.

### 5.3 Transport

When transporting the scanner, remove the feeder from the scanner and pack it in the original packing material.

## 6. Specifications

Film:	35 mm slide mount of 1.0 to 3.2 mm in thickness
Maximum number of slides:	Approx. 50 slides with mounts 1.5 mm in thickness (Housing space: Approx. 78.5 mm)
Operating mode:	LS-2000 installed on its base, SF-200 connected directly to the connector at rear of LS-2000 adapter slot
Feed/eject time (reference):	
Feed:	approx. 6 seconds per slide
Eject:	approx. 6 seconds per slide
Dimensions:	142.0 mm (W) × 324.5 mm (D) × 85.5 mm (H) (5.63" × 12.78" × 3.37")
Weight:	Approx. 700 g (1 lb 9.0 oz)
Power supply:	5 VDC, 0.7 A or less, supplied from scanner
Operating environment:	
Operating temperature	+ 10°C to +35°C
Humidity	20% to 85% (no condensation)